

Wald L., A conceptual approach to the fusion of earth observation data. Surveys in Geophysics, Springer Netherlands, Vol. 21, 177-186, 2000.

A CONCEPTUAL APPROACH TO THE FUSION OF EARTH OBSERVATION DATA

Lucien Wald

April 1999

Ecole des Mines de Paris

BP 207, F-06904 Sophia Antipolis

- o0o -

Abstract

Data fusion is a subject becoming increasingly relevant as scientists try to extract more and more information from remotely sensed data using their synergy. A definition of data fusion is proposed, which allows to set up a conceptual approach to the fusion of Earth observation data by putting an emphasis on the framework and on the fundamentals in remote sensing underlying data fusion instead of on the tools and means themselves, as is done usually.

Further definitions are given, which describe the objects intervening in any problem of data fusion. Fusion may be performed at different levels, simultaneously: measurement level (also improperly called pixel level), at attribute level, and at rule, or decision, level. It is shown that any process of fusion should deal with the selection of the representation space, the level of fusion and the processing to be applied onto the sources of information. The various architectures of fusion systems are presented. Their properties are discussed, including aspects in accuracy, time-consuming, operational constraints. From these basic architectures, more complex systems can be built, which are suitable to a given application.

1.

Definitions

1.1

Introduction

The quantity of information available to describe our environment increases rapidly. Archives are growing, as well as the number of space missions devoted to Earth observation. Many observation systems are presently available, including space-borne, imaging or not, sensors of optical or radar type, which provide various measurements, partly redundant, partly complementary. Data fusion is a subject becoming increasingly relevant as scientists try to extract more and more information from these measurements. Indeed, it is generally correct to assume that improvements in terms of classification error probability, rejection rate, and interpretation robustness, can only be achieved at the expenses of additional independent data delivered by more separate sensors. Data fusion allows to formalise the combination of these measurements, as well as to monitor the quality of information in the course of the fusion process.

Data fusion is a recent word. It means an approach to information extraction spontaneously adopted in several domains. However the operation by itself is not new in remote sensing: classification procedures are performed since long and are obviously relevant to data fusion. Data fusion means a very wide domain. It gathers a large number of methods and mathematical tools, ranging from spectral analysis to plausibility theory. Fusion is not specific to a theme or an application. On the contrary the tools used in a fusion process for a specific application may be tailored to that case.

A formal framework is mandatory for a better understanding of data fusion fundamentals and of its properties. It allows a better description and formalisation of the potentials of synergy between the remote sensing data, and accordingly, a better exploitation of these data.

1.2

Definition of data fusion

Data fusion is a formal framework in which are expressed means and tools for the alliance of data originating from different sources. It aims at obtaining information of greater quality; the exact definition of 'greater quality' will depend upon the application.

Data fusion is exploited by a large number of biological systems. An illustration is given by the human system which calls upon its different senses to perceive its environment. Acquired information is fused within the brain, which will use its memory, its experience, *a priori* knowledge and its reasoning capabilities to perform deductions and produces a representation of the environment.

Data fusion is for example, used to improve results from classification, or control laws and their robustness. It is applied in various domains, ranging from image processing in medicine to management and control of industrial processes.

In data fusion, information may be of various nature: it ranges from measurements to verbal reports. This illustrates the difficulties encountered in data fusion. Some data cannot be quantified; their accuracy and reliability may be difficult to assess. In Earth observation domain, one may use some features held in a geographical information system (external knowledge) to help in classifying multispectral images provided by several sensors. In this particular case, some data are measurements of energy, and others may be symbols.

In the definition given above, quality has not a very specific meaning. It is a generic word denoting that the resulting information is more satisfactory for the « customer » when performing the fusion process than without it. For example, a better quality may be an increase in accuracy of a geophysical parameter or of a classification. It may also be related to the production of a more relevant information of increased utility, or to the robustness in operational procedures. Greater quality may also mean a better coverage of the area of interest, or a better use of financial or human resources allotted to a project.

This document mostly deals with the fusion of data from sensors. It is also called sensor fusion. In this case, information to be fused, are acquired by sensors that can be described precisely. Image fusion is a sub-class of sensor fusion.

1.3

Other definitions

According to this definition, spectral channels of a same sensor are to be considered as different sources, as well as images taken at different instants. Hence, any processing of data acquired by the same sensor is relevant to the data fusion domain. Examples in Earth observation are classification of multispectral imagery, computation of the NDVI (normalised difference vegetation index), or atmospheric correction of spectral bands using other bands of the same sensor. Any processing of time-series of data acquired by the same sensor or different sensors, is a fusion process.

The terms merging, combination will be used in a much broader sense than fusion, with combination being even broader than merging. These two terms define any process that implies a mathematical operation performed on at least two sets of information. These definitions are intentionally loose and offer space for various interpretations. Merging or combination are not defined with an opposition to fusion. They are simply more general, also because we often need such terms to describe processes and methods in a general way, without entering details. Integration may play a similar role though it implicitly refers more to concatenation (*i.e.* increasing the state vector) than to the extraction of relevant information.

Another domain pertains to data fusion: data assimilation or optimal control. Data assimilation deals with the inclusion of measured data into numerical models for the forecasting or analysis of the behaviour of a system. A well-known example of a mathematical technique used in data assimilation is the Kalman filtering. Data assimilation is daily used for weather forecasting.

Terms like measurements, attributes, rules or decisions, are often used in data fusion. These terms as well as others related to information are defined in the following. These definitions are those used in information theory and have been found in several publications.

Measurements are primarily the outputs of a sensor. It is also called signal, or image in the 2-D case. The elementary support of the measurement is a pixel in the case of an image, and is called a sample in the general case. By extension, measurement denotes the raw information. For example, a verbal report is a piece of raw information, and may be considered as a signal. In remote sensing, in the visible range, the measurements are digital numbers that can be converted into radiances once the calibration operations performed. If corrections for the sun angle are applied, one may get reflectances which are still considered as signal.

An object is defined by its properties, e.g., its colour, its materials, its shapes, its neighbourhood, etc. It can be a field, a building, the edge of a road, a cloud, an oceanic eddy, etc. For example, if a classification has been performed onto a multispectral image, the pixels belonging to the same class can be spatially aggregated. This results into a map of objects having a spatial extension of several pixels. By extension, the support of a signal (e.g., a pixel) may be considered as an object.

An attribute is a property of an object which describes geometrical, topological, thematic or other characteristics. Feature is equivalent to attribute. For example, the classification of a multispectral image allocates a class to each pixel; this class is an attribute of the pixel. The equivalent terms label, category or taxon are also used in classification. Another well-known example is the spatial context of a pixel, computed by local variance, or structure function or any spatial operator. This operation can be extended to time context in the case of time-series of measurements. Equivalent terms are local variability, local fluctuations, spatial or time texture, or pattern. By extension, any information extracted from an image (or mono-dimensional signal) is an attribute for the pixel or the object. The aggregation of measurements made for each of the elements of the object (for example, the pixels or samples constituting the object), such as the mean value, is an attribute. Some authors call mathematical attribute such attribute deriving from statistical operations on measurements.

The properties of an object constitute the state vector of this object. This state vector describes the object, preferably in a unique way. The state vector is also called feature vector, or attribute vector. The common property of the elements of the state vector is that they all describe the same object. If the object is a pixel (or a sample), the state vector may contain the measurements as well as the attributes extracted from the processing of the measurements.

Works in pattern recognition have drawn an analogy with the syntax of a language. Terms of higher semantic content have been defined, such as rules and decisions. Rules, like the syntax rules in language, define relationships between objects and their state vectors, and also between attributes of a same state vector. Rules may be state equations, or mathematical operations, or methods (that is a suite of operations, *i.e.* of elementary rules). They may be expressed in elaborated language. Known examples of such rules are those used in artificial intelligence and expert-systems. Decisions result from the application of rules on a set of rules, objects and state vectors.

Usually, fusion of measurements results into attributes, and fusion of attributes into decisions. It is not always straightforward. Let take the case of the ARSIS concept which increases the spatial resolution of a multispectral image given another image of a better resolution not necessarily acquired in the same spectral bands^{1 2}. It intends to simulate what would be observed by a multispectral sensor having a better spatial resolution. Accordingly, it simulates measurements through a fusion process and inference models. However, the results are not measurements, and are attributes. Since they are obtained at each pixel, and since the calibration is taken into account during the process, these attributes are similar to actual measurements. This illustrates that data fusion may be heterogeneous: the sources may not belong to the same semantic class (measurements, attributes, decisions).

1.4

Topological and processing issues

A fusion system can be a very complicated system. It is composed of sources of information, of means of acquisition of this information, of communications for the exchange of information, of intelligence to process the information and to issue information of higher content. The issues involved may be separated in topological and processing issues. Despite the interconnection between both issues in an integrated fusion system design, they can be decoupled from each other in order to facilitate the development of a systematic methodology of analysis and synthesis of a fusion system according to Thomopoulos^{3 4}.

The topological issues address the problem of spatial distribution of sensors, the communication network between sensors and places of processing and decision-making, bandwidth and global architecture. Also at stake are issues for the exchange of information, the availability and reliability of information at the time of the fusion. The cost of acquiring the information may also be relevant to the topological issues. In remote sensing, these issues are partly addressed by the space agencies and by the image vendors. It is also partly addressed by the customer, given its objectives and constraints, including the financial budget.

The processing issues address the question of how to fuse the data, *i.e.* select the proper measurements, determine the relevance of the data to the objectives, select the fusion methods and architectures, once the data are available, and according to the specifications issued by the project under concern. These issues are mathematically expressed in Pau⁵.

¹ T. Ranchin, L. Wald, and M. Mangolini, "The ARSIS method: a general solution for improving spatial resolution of images by the means of sensor fusion," in Proceedings of the 1st conference "Fusion of Earth data: merging point measurements, raster maps and remotely sensed images", Thierry Ranchin and Lucien Wald Editors, published by SEE/URISCA, Nice, France, pp. 53-58, 1996.

² T. Ranchin, and L. Wald, "Sensor fusion to improve the spatial resolution of images : the ARSIS method," in : Proceedings, EARSeL Symposium 1997 "Future Trends in Remote Sensing", Lyngby, Denmark, P. Gudmansen Ed., A. A. Balkema Publ., pp. 445-451, 1998.

³ S. C. A. Thomopoulos, "Sensor integration and data fusion," *Journal of Robotic Systems*, vol. 7, pp. 337-372, 1990.

⁴ S. C. A. Thomopoulos, "Decision and evidence fusion in sensor integration," in *Advances in Control and Dynamic Systems*, Ed. C. T. Leondes, vol. 49, part 5, pp. 339-412, Academic Press, 1991.

⁵ L. F. Pau, "Sensor data fusion," *Journal of Intelligent and Robotics Systems*, vol. 1, pp. 103-116, 1988.

1.5

Some properties

Several problems are to be solved prior to any process of fusion ^{6 7}. The information entering a fusion process should present several properties which are now described. Some notations first:

- S is the set of NS sensors and sources of information $S=\{S_i, i=1...NS\}$
- $(z_s)^t$ is the set of measurements made by the NS sensors at instant t
- $(X_s)^t$ is the representation of the object at instant t by the NS sources

A representation of the object is the set of measurements, or attributes, or rules describing the object, completely or not. In principle, a representation consists in all the knowledge available about this object, given the set of sensors S . A representation includes the state vector of the object together with the relevant rules.

1.5.1

Alignment

Define a common representation (X_s) on the basis of the measurements $(z_s)^t$, and the representations $(X_s)^t$. Differently said, a common co-ordinate system (e.g., geographical space and time) should be found in which the sources data as well as the global knowledge can be represented. The data are said aligned, and the relevant operations are called alignment operations or process. This is called alignment, or conditioning, or positional data fusion.

For example, geocoding airborne or space-borne images is part of the alignment operation. Similar mathematical techniques can be applied to other types of images in different domains, such as medicine or industrial process.

Alignment should provide a general frame of referencing that can applied to homogeneous (commensurate) as well as heterogeneous (non-commensurate) data. This is a difficult problem, and there is no general theory. Even in the simple case of measurements of radiances, which are commensurate, it may still be not straightforward. Though having the same space reference, two sources may not refer to the same object (landscape). In the Meteosat case, the water vapour channel does not provide any information on the ground, while the visible and infrared channels do. Another example in oceanography is the fusion of observations of sea surface temperature, which are relevant to the very surface of the ocean, and of ocean colour, which are depth-integrated.

This concept of alignment is extended to a wider reference space (representation space) which also includes standardisation of units, calibration of sensors and atmospheric corrections, etc., if necessary. The alignment problem calls upon physics, and is certainly the problem in data fusion which is the most relevant to the concerns of the remote sensing community.

1.5.2

Association

Let be two sets of sensors $S(1)$ et $S(2)$. Each provides a representation, $(X_{S(1)})^t$ and $(X_{S(2)})^t$. Let be S , the union set of sensors. Assume information is aligned for this set S . Associating the two representations $(X_{S(1)})^t$ and $(X_{S(2)})^t$ requires that they refer to the same object. The union of the representations is called association or concatenation. Association is made by an increase of the size of the state vector of the object.

Data concatenation is accomplished easily and straightforward by juxtaposing all the data into the state vector, hence augmenting it. An example is given by a time-series of images from the geostationary satellite Meteosat. The raw data are processed by Eumetsat, and are spatially superimposable once delivered to the customer. In that case, at each pixel, one can define a state vector by the concatenation of all the observations made at this pixel in the period under concern. Because the data provider has performed the alignment of data, the customer deals in this case with concatenation and subsequent analysis.

⁶ L. Castagnas, "De la synergie des images satellitaires SPOT / ERS au travers de deux exemples de fusion". Thèse de Doctorat, Univ. Nice - Sophia Antipolis, France, 139 p., 1995.

⁷ L. F. Pau, "Sensor data fusion," *Journal of Intelligent and Robotics Systems*, vol. 1, pp. 103-116, 1988.

Some examples have been given in the previous section, where sources are not exactly referring to the same object. In that case, though the sources are aligned, the representations cannot be associated.

In some case, the problem can be the selection of sub-sets of sensors, which are the most relevant for a given problem. A metric should then be defined for the comparison between sensors, and the choice of the most appropriate ones.

1.5.3 Fusion of attributes

Assume the information has the properties of alignment and association. Fusion of attributes consists in merging the attributes of a same object, derived from two representations $(X_{S(1)})^t$ et $(X_{S(2)})^t$ obtained by means of the sensors $S(1)$ and $S(2)$, in order to obtain new attributes in the space of sensors $S = S(1) \cup S(2)$.

1.5.4 Fusion of analysis

Assume the information has the properties of alignment and association. Fusion of analysis consists in aggregating representations $(X_{S(1)})^t$ and $(X_{S(2)})^t$, into a new representation $(X_S)^t$, then in generating an analysis / interpretation of the object for further use at instant $(t+1)$, or at step i in an iterative process.

1.5.5 Fusion of representations

Fusion of representations is defining and performing meta-operations applicable to representations $(X_{S(1)})^t$ and $(X_{S(2)})^t$ to obtain a new representation $(X_S)^t$. For example, fusion of classification. Fusion of representations includes fusion of decisions. This fusion of representations may be performed at any moment, *i.e.* combined with other types of fusion..

This implies that fusion may operate at any of the three semantic levels, with possible crossings between levels:

- measurements (fusion of measurements)
- attributes (fusion of attributes)
- rules (fusion of decision or rules)

2. Representing a fusion process and architectures

2.1

Representing a fusion operations

Several formalisms have been proposed. It is usually proposed to consider three levels in data fusion: pixel, attribute and decision^{8 9}. They are also called low level, middle level and high level. It presents two drawbacks. The pixel is only a support of information and has no semantic significance. Measurements or observations would be more appropriate. But overall, it does not consider fusion processes dealing simultaneously with these different levels. The various nature of the information to be fused has already been emphasised. The definition of fusion of representations also stresses that fusion can operate at the three different levels with possible mixing. Accordingly, the formalism of Houzelle, Giraudon¹⁰ is preferable and is adopted here. It allows all semantic levels (measurements, attributes, decisions) to be simultaneous inputs of a fusion operation.

A fusion operation can be decomposed into elementary operations. Each elementary can be represented by the means of the fusion cell in Figure 2.1.1. Actually, this cell may also represent very complex operations.

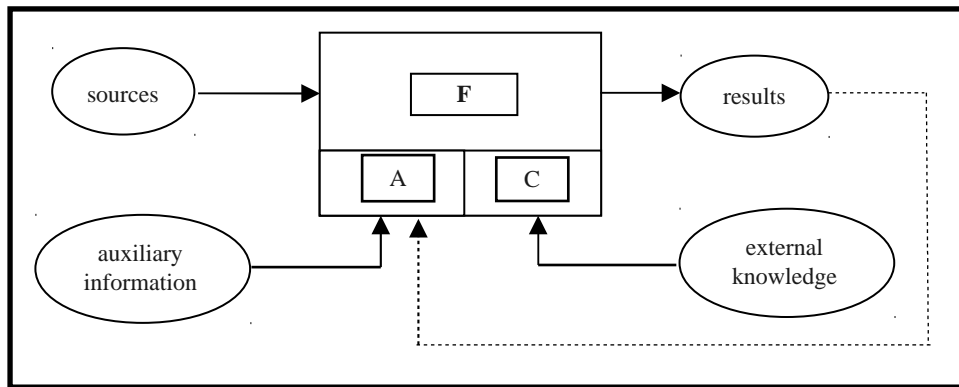

Figure 2.1.1. Formalisation of an elementary fusion operation by a fusion cell

Sources of information, *i.e.* the measurements provided by the sensors and more generally the original information, are the main inputs of the fusion cell. The auxiliary information bring additional information, resulting from the specific processing of a source, or from another fusion operation. External knowledge is also additional information, whose objective is mainly to constrain or guide the fusion process by *e.g.*, imposing the respect of *a priori* knowledge. In iterative processing, including time-dependent operations, results may become inputs to the fusion operation in a subsequent step or instant. They will act as auxiliary information, since they are not original sources.

Let give a simple example. The sum is a fusion operation. Let be two measurements of similar type: **a** and **b**. The sum **d**:

$$d = a + b$$

can be represented like in Fig. 2.1.2a.

⁸ M. Mangolini, Apport de la fusion d'images satellitaires multicapteurs au niveau pixel en télédétection et photo-interprétation. Thèse de Doctorat, Université Nice - Sophia Antipolis, France, 174 p., 1994.

⁹ C. Pohl, and J. L. van Genderen, "Multisensor image fusion in remote sensing: concepts, methods and applications", *International Journal of Remote Sensing*, vol. 19, n° 5, pp. 823-854, 1998.

¹⁰ S. Houzelle, and G. Giraudon, "Contribution to multisensor fusion formalization," *Robotics and Autonomous Systems*, vol. 13, pp. 69-85, 1994.

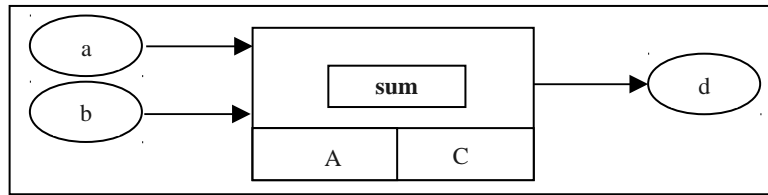

Figure 2.1.2a. Example of a sum

Consider now the following operation:

$$\begin{aligned} d &= a+b && \text{if } c > 0 && \text{with } c = \ln a \\ d &= a-b && \text{otherwise} \end{aligned}$$

c is a knowledge derived from original information, *i.e.* an auxiliary information. Accordingly the fusion is represented as in Fig. 2.1.2b:

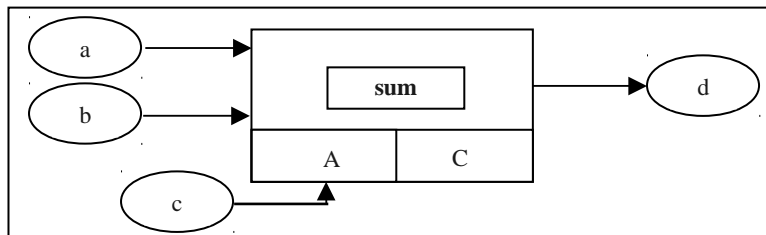

Figure 2.1.2b. Example of a sum depending from an auxiliary information

If **c** is an external knowledge, e.g., a threshold given *a priori*, the operation is then:

$$\begin{aligned} d &= a+b && \text{si } a > c \\ d &= a-b && \text{sinon} \end{aligned}$$

and is shown in Figure 2.1.2c.

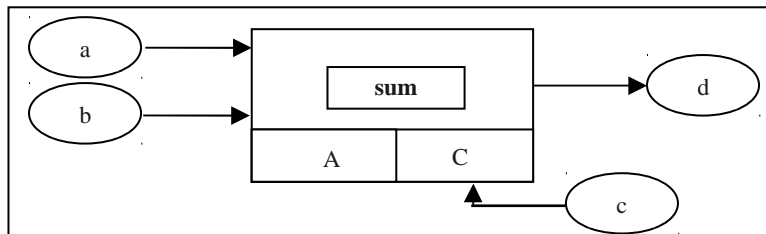

Figure 2.1.2c. Example of a sum depending from an annex information

Another example is given in Figure 2.1.3. There, several sensors are monitoring an industrial process. Their measurements are fused. The process is controlled *via* control laws, which are inputs as annex knowledge, in order to guide or constrain the fusion. The outputs may be attributes or decisions.

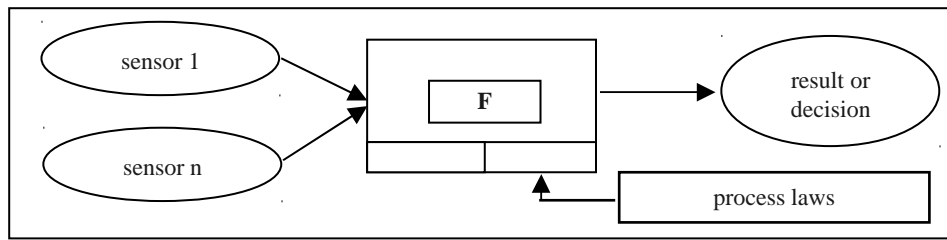

Figure 2.1.3. Scheme for an industrial process

The engine of a modern vehicle works along this scheme. The process laws are called 'engine cartography'. The sensors measure e.g., temperature, pressure and flow in different places. The result may be the quantity of gas to be injected into the combustion chamber.

The process laws may take into account the history of each measurement or result. In that case, history becomes an input as an annex knowledge. Figure 2.1.3 may also represent the monitoring of an object, e.g., of the trajectory of a rocket. This requires the outputs of the fusion cell to become inputs for the following instant, as auxiliary information (see dotted lines in Figure 2.1.1). The fusion cell may consist in a Kalman filter.

Mapping from satellite images is the last example of this section (Fig. 2.1.4). Several images of different natures (optics, radar) are inputs to the fusion cell. The fusion method is a classifier, and outputs are maps of classes and confidence level. From the image of best spatial resolution (SPOT-P in this example), an image of texture is extracted. This image is an auxiliary information, and will help to classify the original measurements. If geographical information is available, too, it will increase the quality of the results if it is an input of the cell as an annex knowledge.

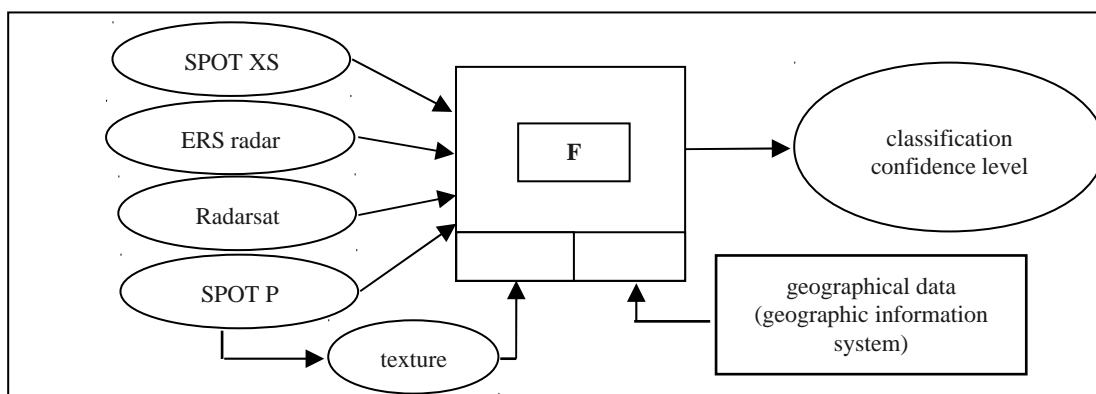

Figure 2.1.4. Mapping from satellite images

In the following example (Fig. 2.1.5), colour images should be transmitted. The three channels are called R (red), G (green), and B (blue). The images are originally coded in 24 bits (3x8). Compression should be applied before transmission and compressed images are coded in 8 bits. The compression / re-coding algorithm calls upon rules, which are fixed but changes should be brought if necessary. The algorithm should also respect the main contours and some of the coloured transitions. Accordingly, one input of the algorithm is an index ID, computed from a mathematical combination of the wavelet coefficients (C1, C2) and of a quantity Q. The wavelet coefficients are obtained by two iterations of a wavelet transform WT applied to the intensity I of the images. The quantity Q is defined as follows

- $Q = R - G$ if the saturation is greater than S_0
- $Q = R - B$ otherwise

The threshold S_0 is fixed but changes should be brought if necessary. The architecture is shown in Figure 2.1.5.

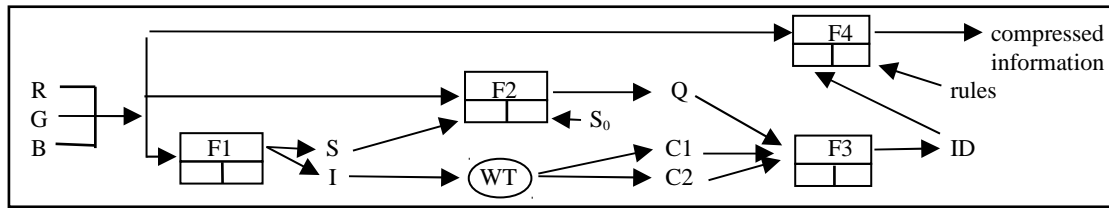

Figure 2.1.5. Another example of architecture, for data compression

For the same example, the architecture may also be represented using a more condensed scheme, as in Figure 2.1.6.

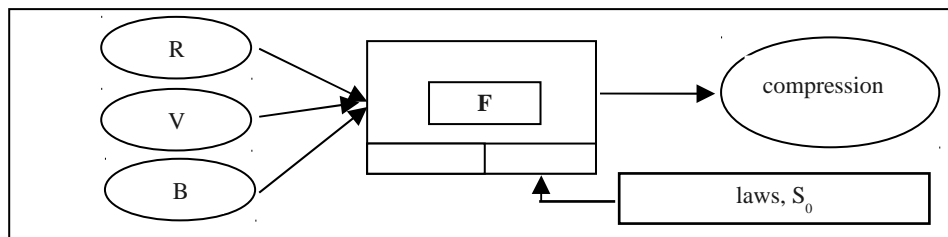

Figure 2.1.6. Another scheme for the same operation for compression

2.2

Architectures

A fusion architecture describes the set of sensors, how they are assembled, and how they are used, together with mathematical techniques and processing, in order to perform a fusion operation. Usually three types of architectures are defined: centralised, decentralised and hybrid.

The centralised architecture exploits in a single location, simultaneously or not, the set of data acquired by the set of sensors. In Fig. 2.2.1, S_i are the n sources. A source can be a set of measurements, attributes or decisions. All sources are inputs of the single fusion cell. The results R and quality parameters Q are obtained by the processing of all sources available at that moment. Of course, this architecture may include auxiliary information and external knowledge.

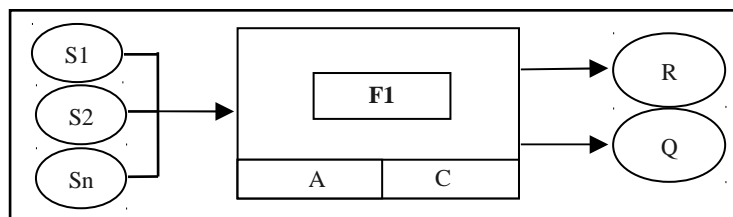

Figure 2.2.1. Centralised architecture. S_i are the sources, R and Q the results and quality parameters

The advantage of the centralised architecture is that it theoretically provides an optimal result, since decision is made taking into account the whole knowledge available. However, if a particular sensor has a large error rate or a low signal-to-noise ration, according to the fusion operation, it may happen that this sensor contaminates the whole data set, and leads to a decrease of the quality of the decision, compared to what would have been achieved without it.

In Earth observation, such cases may be encountered, as e.g., imaging radar whose image quality is a function of various parameters, such as the rainfall before the instant of acquisition, or the surface state of the water bodies. In most cases, using radar images as inputs to a fusion operation will be highly profitable. In some cases, it may decrease the quality of the result: if a wind is strong, rice fields cannot be perceived at certain growth states,

hal-00465627, version 1 - 20 Mar 2010

because the clutter due to the wavelets make them confusing with other objects in the landscapes. It is more profitable to adopt another architecture.

The centralised architecture has some drawbacks with respect to processing. It requires all the data to be present on the processing site, which implies large communication bandwidth. It also imposes a heavy processing load on the computer, which renews at any change of an input.

The decentralized architecture offers a large flexibility and modularity, and is often adopted for these reasons. It is also called autonomous because it involves independent processing of each source of information (or group of sources) until the fusion of some representation of higher semantic level takes place at a later stage (Fig. 2.2.2).

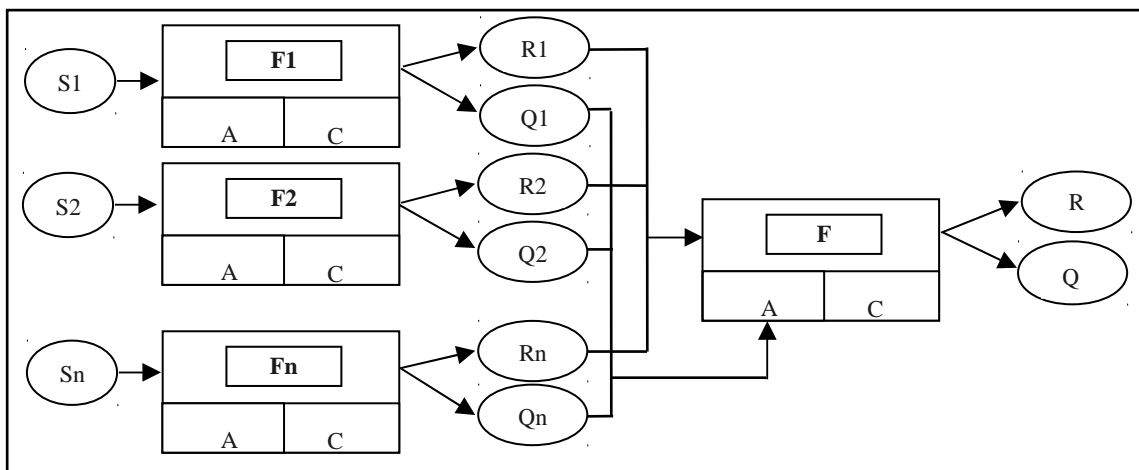

Figure 2.2.2. Decentralised architecture

It should be selected when communication problems are at stake: small bandwidth, unsecure communications, which may be broken, etc. If the acquisition rate of information (sources) is very different between all sources, it may also be adopted to avoid re-processing all the sources while a few have changed, which is the case in the centralized scheme. The decentralized architecture will be adopted in risky domains, such as a battlefield or industrial hazards.

Each source S_i enters a fusion cell, which may also include auxiliary information and external knowledge. As said before, a source S_i is a set of inputs, which are composed of measurements, attributes, and / or decisions. The local fusion cells ($F_1, F_2... F_n$) result into results R_i and quality parameters Q_i . These results and quality parameters are transmitted to the final fusion cell F . The results R_i are the inputs of this process. The quality parameters Q_i are auxiliary information and will help in deciding the weight of a source in the final process.

One may note that each fusion process F_i is performed locally, using local intelligence. The fusion processing usually reduces the amount of information to be transmitted to the final fusion process. This accommodates for low communications bandwidth. One may also note that this scheme is more robust to the loss of a source of information than the centralized scheme. From a practical point of view, it is easy with such architecture to remove, or not to take into account, a sensor whose confidence is questionable. It is much more difficult with a centralized architecture. In the case of strongly asynchronous information acquisition, i.e. very different time sampling of information from each source, this architecture gathers the locally fused information at the final central point, and thus does not need to renew the whole process at each acquisition time of the most rapid source.

The sources are processed independently from the others. Accordingly the results locally available R_i have a fairly low information content, depending upon the sources. It further results in the fact that the final result R has

a lower quality and a lower information content than that would have been achieved with a centralized architecture.

Other architectures may be designed, which is combination of centralized and decentralized architectures. They are called hybrid architectures and have various forms (Fig. 2.2.3).

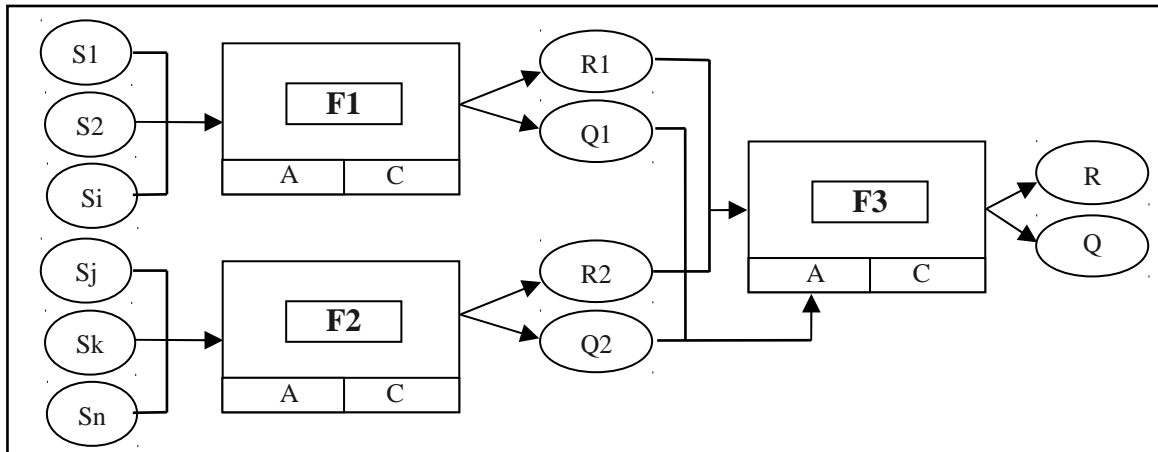

Figure 2.2.3. Hybrid architecture

In this Figure, the sources S_1, S_2, \dots, S_n are separated in two sub-sets: S_1, \dots, S_i , and S_j, \dots, S_n with possible overlaps. Each sub-set enters a fusion process having a centralized architecture. The results R_1 and R_2 are the sources of a final fusion process F , with the quality parameters Q_1 and Q_2 as auxiliary information.

Such architectures involve fusion of the sources at different semantic levels and at different processing stages. Depending upon the combination, such architecture is more or less close to a centralized or decentralized architecture, and so are its properties (advantages and drawbacks).

As a conclusion regarding the architectures, each architecture has advantages and drawbacks. They should be selected on a case by case basis. Trade-off involve many factors¹¹, including the availability of smart sensors that perform data preprocessing, the availability of communications links and their bandwidth, and the computational abilities of the central processor / decentralized processors.

¹¹ D. Hall. *Mathematical techniques in multisensor data fusion*. Artech House, Boston, London, 1992.